



Equipped with AEM® Dryflow™ Filter  
No Oil Required!

# INSTALLATION INSTRUCTIONS

## PART NUMBER: 21-8311

---

1997-2006 JEEP Wrangler L6-4.0L C.A.R.B. E.O. # D-670

\* **NOTE: Legal in California only for racing vehicles which may never be used upon a highway**

## PARTS LIST

	Description	Qty.	Part Number
A	Air Filter Assy. 3.00 X 9" Dry Ele.	1	21-2039DK
B	Heat Shield	1	20-8300
C	Inlet Pipe	1	2-83111
D	Hose, Adapter 2.75/3.00 X 2-5/8	1	5-273-J
E	Hose; 5/8"ID X 11"L	1	5-7011
F	Edge Trim, 18"	1	8-4018
G	Mount, Rubber 1" X 6mm	1	1228599
H	Spacer, .500 OD X .250 ID X 1"	3	2-671
I	TB Spacer	1	2-9000M
J	Gskt., TB Spacer	2	2-9200
K	Zip Tie, 8" Tree Push-Mnt.	1	1-127
L	Plug, 7/8"	1	8-132
M	Grommet, 1/2"	1	784634
N	Bolt, Hex/Flange M8-1.25 X 20	1	1-2025
O	Bolt, Hex/Flange M6-1 X 50	4	1-2070
P	Bolt, Hex/Flange M6-1 X 40	3	1-2075
Q	Washer, 8mm Soft Mount	2	559960
R	Washer, 6mm Soft Mount	2	559999
S	Nut, M6 Hex Serrated	2	444.460.04
T	Nut, M8 Hex Serrated	1	444.460.08
U	1/2" Bnd. Hose Clamp, 2.31-3.25"	1	9444
V	1/2" Bnd. Hose Clamp, 2.56"-3.50"	1	9448
W	Hose Clamp, 1"	2	99024.032
X	1/2" Bnd. Hose Clamp, 2.90"-3.75"	1	9452

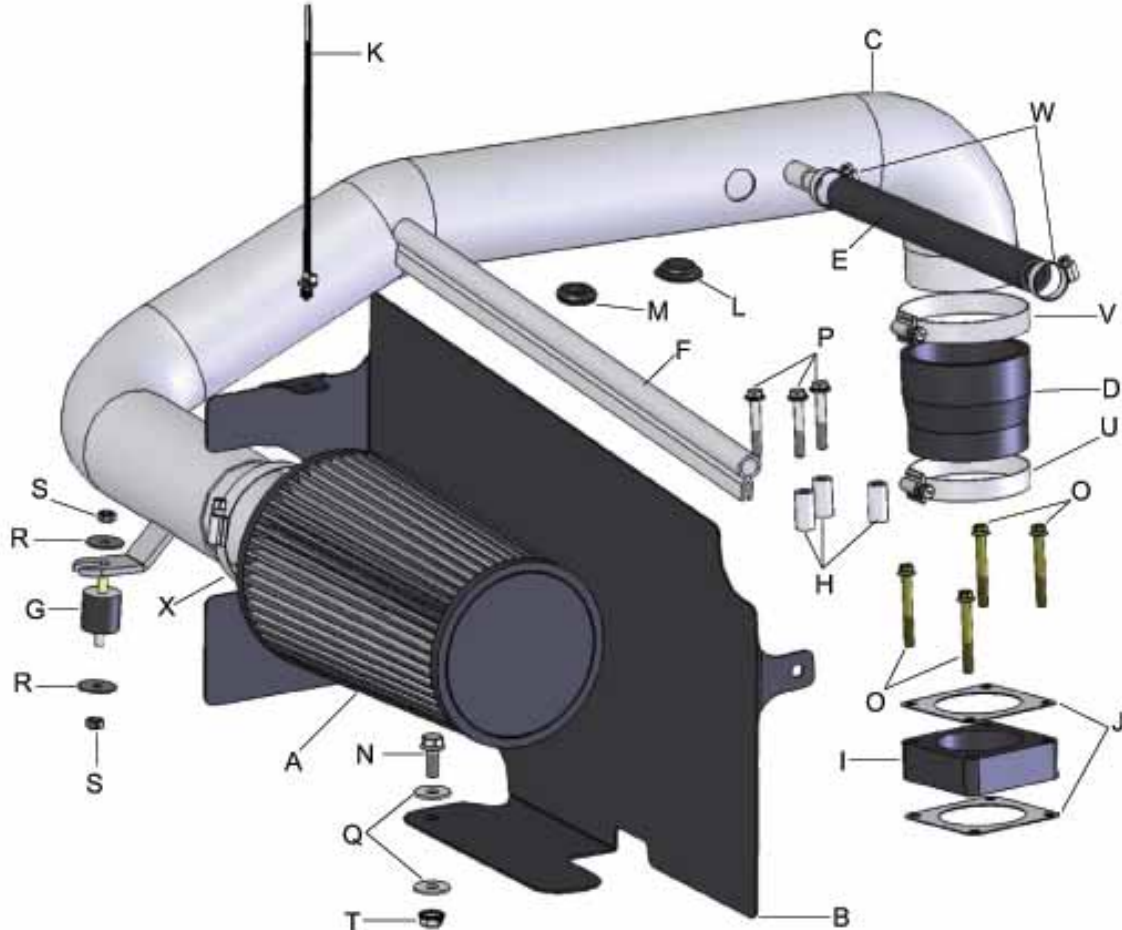

Read and understand these instructions **BEFORE** attempting to install this product. Failure to follow installation instructions and not using the provided hardware may damage the intake tube, throttle body and engine.

## 1. Preparing Vehicle

- a. Make sure vehicle is parked on level surface.
- b. Set parking brake.
- c. If engine has run in the past two hours, let it cool down.
- d. Disconnect negative battery terminal.
- e. Do not discard stock components after removal of the factory system.

## 2. Removal of stock system



a. Factory air box configuration for Jeep Wrangler.



b. Loosen the hose clamp located at the throttle body.



c. 2005-2006 Vehicles: Push in and twist the "Inlet Air Temperature" sensor out of the intake tube.  
1997-2004 Vehicles: Proceed to the next step and disregard this step.



d. Loosen the hose clamp connecting the intake tube to the air filter lid.



e. Remove the air filter lid from the air filter housing. Unclasp the four retaining clasps. Also be sure to disconnect the crank case breather hose from the lid.



f. This is the intake tube and air filter lid after removal from the vehicle.



g. Remove the three bolts securing the bottom half of the air box to the vehicle.



h. The factory air box housing removed.

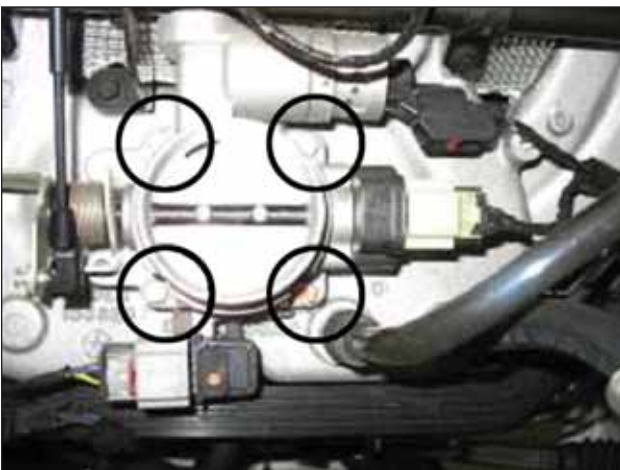

i. Remove the four bolts securing the throttle body to the intake manifold. After removal of the four bolts, place the throttle body spacer between the throttle body and the intake manifold. Install with the supplied gaskets and bolts, refer to the diagram on page 2 for the gasket placement.



j. 2000-2006 Vehicles: Remove the 2 bolts on the throttle body linkage and replace with the supplied bolts and spacers.  
1997-1999 Vehicles: Locate the 3 bolts attaching the throttle body linkage and replace with the 3 supplied bolts and spacers.



### 3. Installation of AEM® intake system.

a. When installing the intake system, do not completely tighten the hose clamps or mounting hardware until instructed to do so.



b. Secure the reducing coupler to the throttle body using the supplied #44 and #48 hose clamps.

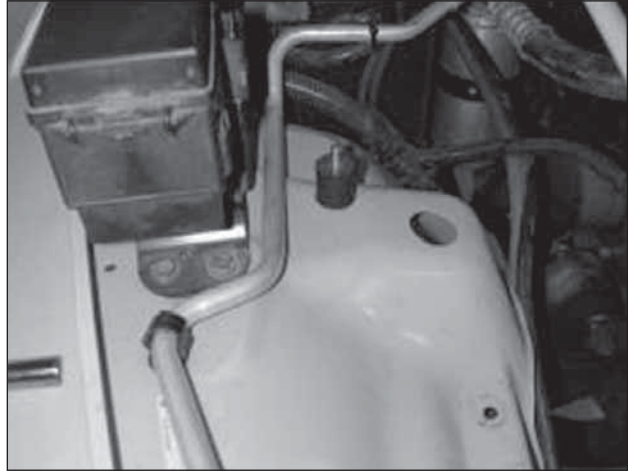

c. Install the supplied 6mm rubber mount. Use the supplied 6mm nut and 6mm washer. Attach the bolt and secure from underneath the fender well.

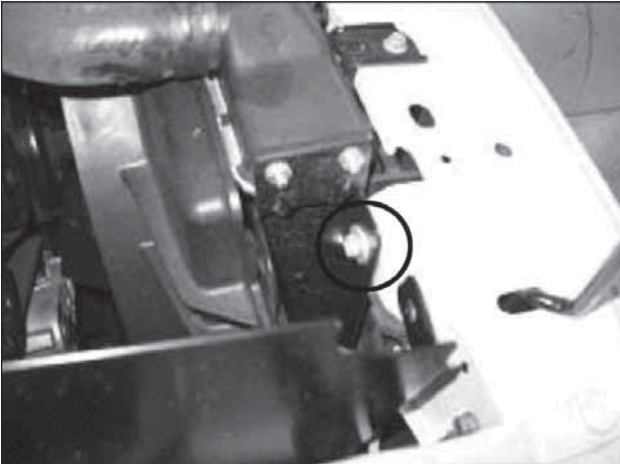

d. Remove the bolt securing the radiator to the core support. Slide the heat shield into position and re-insert the stock bolt through the heat shield hole and back through through the radiator support from which it was removed from.



e. 2005-2006 Vehicles: Install the rubber grommet into the intake pipe as shown.  
1997-2004 Vehicles: Install the plug into the intake pipe.



f. Insert the intake pipe into the rubber coupler attached to the throttle body.



g. Align the intake pipe with the heat shield and rubber mount. After alignment is achieved, secure the heat shield with the supplied M8 bolt, washers and nut to the fender well of the vehicle.



h. Secure the intake pipe to the rubber mount by using the supplied 6mm nut and washer.



i. 2005-2006 Vehicles: Carefully install the IAT sensor into the intake pipe.  
1997-2004 Vehicles: Proceed to the next step.



j. Twist the stock nipple carefully until it faces the driver side of the vehicle.



k. Attach the supplied breather hose to the intake pipe and the crank case ventilation nipple. Use supplied 1" hose clamps to secure the hose.



I. Attach the AEM® Dryflow™ air filter to the end of the intake pipe using the #52 hose clamp. Use the supplied zip tie to secure the heat shield to the support bar.



Factory air box system installed



AEM® intake system installed

#### 4. Reassemble Vehicle

- a. Position the inlet pipes for the best fitment. Be sure that the pipes or any other components do not contact any part of the vehicle. Tighten the rubber mount (if applicable), all bolts, and hose clamps.
- b. Check for proper hood clearance. Re-adjust pipes if necessary and re-tighten them.
- c. Inspect the engine bay for any loose tools and check that all fasteners that were moved or removed are properly tightened.
- d. Reconnect negative battery terminals and start engine. Let the vehicle idle for 3 minutes. Perform a final inspection before driving the vehicle.

#### 5. CARB Sticker Placement

- a. The C.A.R.B. exemption sticker, (attached), must be visible under the hood so that an emissions inspector can see it when the vehicle is required to be tested for emissions. California requires testing every two years, other states may vary.



## 6. Service and Maintenance

- a. AEM Induction Systems requires cleaning the intake system's air filter element every 100,000 miles. When used in dusty or off-road environments, our filters will require cleaning more often. We recommend that you visually inspect your filter once every 25,000 miles to determine if the screen is still visible. When the screen is no longer visible some place on the filter element, it is time to clean it. To clean, purchase our Synthetic air filter cleaner, part number 99-0624 and follow the easy instructions.
- b. Use window cleaner to clean your powder coated AEM® intake tube.

**NOTE: DO NOT USE aluminum polish on powder coated AEM® intake tubes.**

For technical inquiries  
e-mail us at  
sales@aemintakes.com  
or  
call us at  
800.992.3000

### AEM Air Intake System Warranty Policy

AEM® warrants that its intake systems will last for the life of your vehicle. AEM will not honor this warranty due to mechanical damage (i.e. improper installation or fitment), damage from misuse, accidents or flying debris. AEM will not warrant its powder coating if the finish has been cleaned with a hydrocarbon-based solvent. The powder coating should only be cleaned with a mild soap and water solution. Proof of purchase of both the vehicle and AEM intake system is required for redemption of a warranty claim.

This warranty is limited to the repair or replacement of the AEM part. In no event shall this warranty exceed the original purchase price of the AEM part nor shall AEM be responsible for special, incidental or consequential damages or cost incurred due to the failure of this product. Warranty claims to AEM must be transportation prepaid and accompanied with dated proof of purchase. This warranty applies only to the original purchaser of product and is nontransferable. Improper use or installation, use for racing, accident, abuse, unauthorized repairs or alterations voids this warranty. AEM disclaims any liability for consequential damages due to breach of any written or implied warranty on all products manufactured by AEM. Warranty returns will only be accepted by AEM when accompanied by a valid Return Merchandise Authorization (RMA) number. Credit for defective products will be issued pending inspection. Product must be received by AEM within 30 days of the date RMA is issued.

If you have a warranty issue, please call (800) 992-3000 and our customer service department will assist you. A proof of purchase is required for all AEM warranty claims.